



# ADVANCED Engineering Solutions



## Main scope

- Dessicant Air Dehumidifiers
- Air Humidifiers
- HVAC Instruments
- Air to Air Heat Exchangers
- Air Particle Counters
- Microbial Air Samplers
- UV Lamps
- Data Loggers

MICRONVIEW



Hygenic & Clean  
Air Sampler



FRAL  
RIGHT HUMIDITY ON DEMAND



AIRFLOW  
INSTRUMENTS

sauermann®





## WHO WE ARE

We are a trusted engineering trading company providing high-quality solutions and products to various industries. Committed to excellence and innovation, we deliver reliable, tailored solutions through a team of experienced professionals who understand market needs and supply advanced technologies.



### OUR **MISSION**

Our mission is to provide innovative and cost-effective engineering solutions to meet the specific needs of our clients. We aim to be a trusted partner in the industry, offering high-quality products, exceptional customer service, and technical expertise.



### OUR **VISION**

To be a leading trading company, recognized for excellence, innovation, and the ability to solve complex challenges, shaping smarter and more sustainable solutions.



### OUR **VALUES**

Integrity, Quality, Sustainability, Customer-Centricity, Collaboration  
Safety, and Innovation



**ADVANCED**  
Engineering Solutions

MICRONVIEW IS AN AMERICAN COMPANY FOUNDED IN 2013 SPECIALIST IN REAL TIME MICROBIAL AND PARTICLE MONITORING TECHNOLOGY FOR CLEANROOMS PHARMACEUTICAL, FOOD, AND BIOTECH ENVIRONMENTS.



## ONLINE AIR PARTICLE COUNTER UNITS



**REMOTE APC WITH TOUCH SCREEN  
WITH VACUUM PUMP**



**REMOTE APC  
WITH VACUUM PUMP**



**REMOTE APC WITH PROTECTIVE  
ENCLOSURE**



**REMOTE APC WITH TOUCH SCREEN AND  
PROTECTIVE ENCLOSURE**

## ONLINE AIR PARTICLE COUNTER SYSTEM

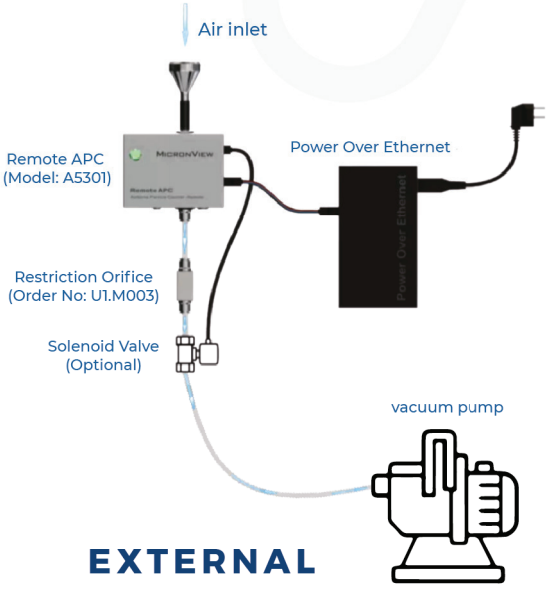

**EXTERNAL  
PUMP**

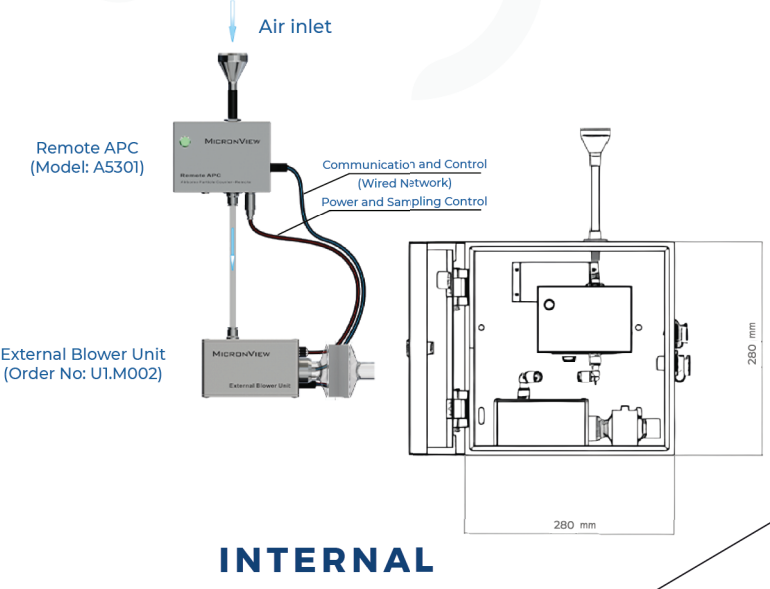

**INTERNAL  
PUMP**



ADVANCED  
Engineering Solutions

## PORTABLE AIR PARTICLE COUNTER

FDA  
21 CFR Part 11



Compressed gas



USB



Wi-Fi



Ethernet (LAN/Internet)



PDF File



- 28.3/50/100 LPM
- 4.2 KG
- AUDIT TRAIL

- DATA STORAGE: 5 MILLION SETS
- 10 YEARS WARRANTY FOR THE LASER DIODE
- VHP RESISTANCE

## MICROBIAL AIR SAMPLER

Compressed gas



### ECO

- FLOW RATE: 100LPM
- STAINLESS STEEL AUTOCLAVABLE HEAD
- WEGHIT 2.9 KG



### AIR SAMPLER WITH H.P.D KIT



### NEO

- DUAL FLOW RATES: 100,200LPM
- STAINLESS STEEL AUTOCLAVABLE HEAD
- WEGHIT 2.5 KG

HYCLAS IS AN ITALIAN MANUFACTURER SPECIALIZING IN MICROBIOLOGICAL AIR SAMPLERS USED IN CLEANROOMS AND CONTROLLED ENVIRONMENTS.



## MICROBIAL MOBILE AIR SAMPLER



The image shows three views of the Microbial Mobile Air Sampler: a front view of the stainless steel unit with a digital display showing '0050 t', a side view showing the sampling head with a hand holding a smartphone nearby, and an open carrying case containing the device and accessories. The FDA 21 CFR Part 11 logo is also present.

- 100/180 LPM
- VHP RESISTANT
- 316L STAINLESS STEEL
- AUDIT TRAIL

## MICROBIAL FIXED AIR SAMPLER

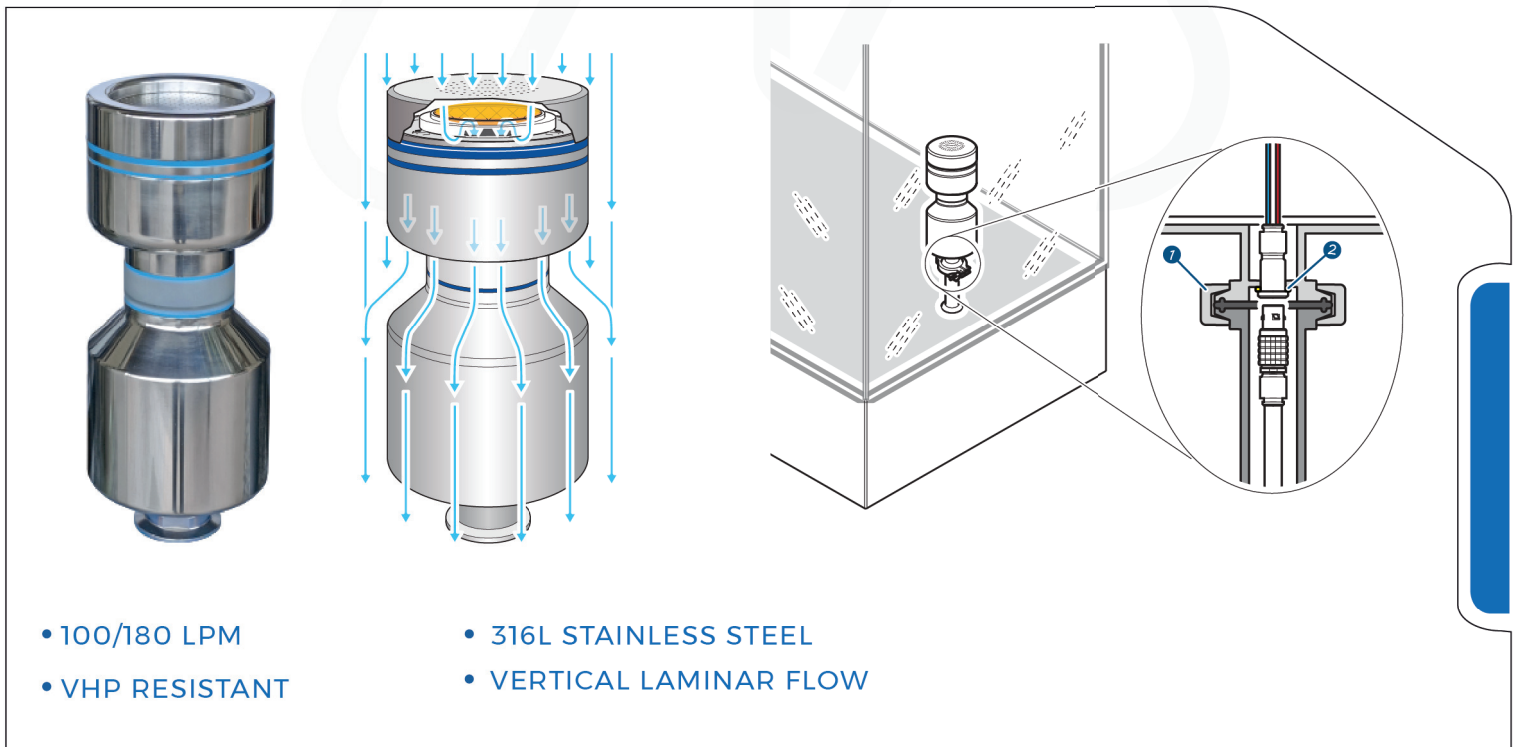

The image shows three views of the Microbial Fixed Air Sampler: a front view of the stainless steel unit, a cross-sectional diagram showing vertical laminar flow with arrows, and a detailed view of the sampling head assembly with numbered callouts 1 and 2.

- 100/180 LPM
- VHP RESISTANT
- 316L STAINLESS STEEL
- VERTICAL LAMINAR FLOW



ADVANCED  
Engineering Solutions

## MICROBIAL AIR SAMPLER CALSSIC - LINE



- 316L STAINLESS STEEL AUTOCLAVABLE HEAD
- EXTREMELY LOW WEIGHT (ONLY 1,5KG)
- SUITABLE FOR ALL PLATES TYPES

- VALIDATED ACCORDING TO ISO 14698 FOR BIOCONTAMINATION CONTROL
- 100/180 LPM

## AIR SAMPLER WITH HIGH PRESSURE DIFFUSER

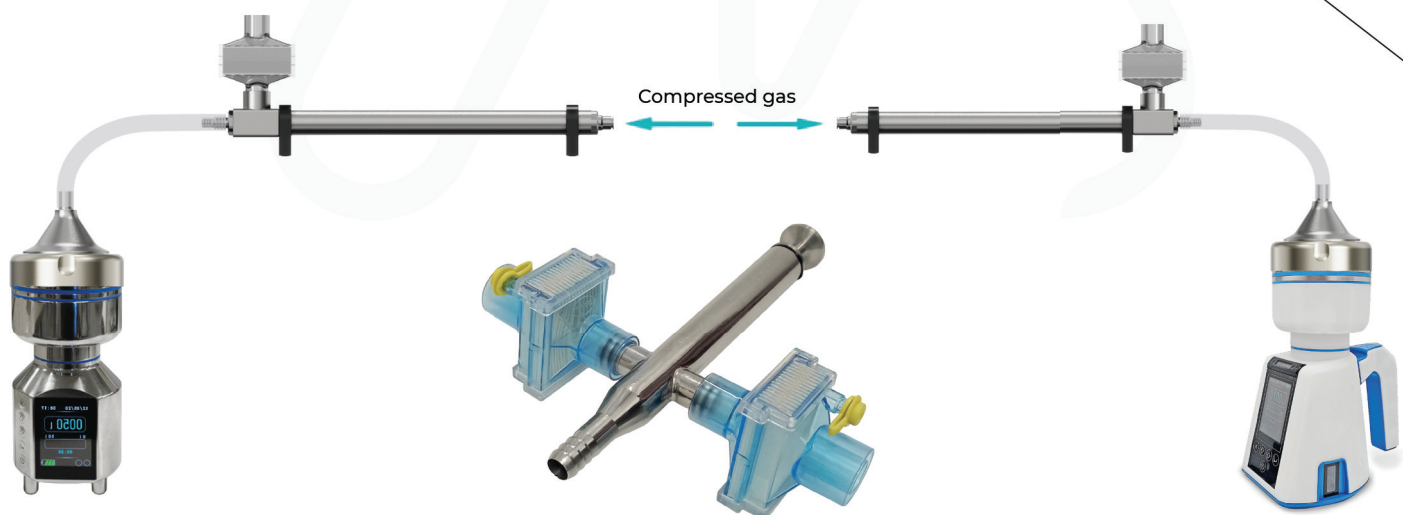

- 316L STAINLESS STEEL
- MAXIMUM WORKING PRESSURE 10BAR

- FLOW RANGE 100 LPM
- COMPRESSED AIR AND GASES



CAREL COMPANY FOUNDED IN 1973 IN BRUGINE IT SPECIALIZES IN HVAC AND REFRIGERATION SYSTEMS THAT OFFERING PRODUCTS LIKE CONTROLLERS, HUMIDIFIERS AND REMOTE MANAGEMENT TOOLS.



## STEAM HUMIDIFIERS



**HUMISTEAM**  
IMMERSED ELECTRODE TYPE  
1.5-130 kg/h



**HUMISTEAM BASIC**  
Simple operation with ON/OFF or proportional control modes.



**HUMISTEAM XPLUS**  
Enhanced connectivity, BMS integration, and advanced safety and diagnostic features.

## WATER HUMIDIFIERS



**HUMIDISK**  
CENTRIFUGAL TYPE  
1 or 6.5 kg/h



**HUMISONIC**  
ULTRASONIC TYPE  
FROM 0.5 TO 18 kg/h

FRAL, FOUNDED IN 1991, IS A LEADING ITALIAN MANUFACTURER SPECIALIZING IN BOTH DESICCANT AND CONDENSATION DEHUMIDIFICATION SYSTEMS FOR INDUSTRIAL, COMMERCIAL AND PHARMACEUTICAL APPLICATIONS.



## DESICCANT DEHUMIDIFIERS

- PROCESS AIR FLOW RATE IN STANDARD UNITS UP TO 25,000 M<sup>3</sup>/H

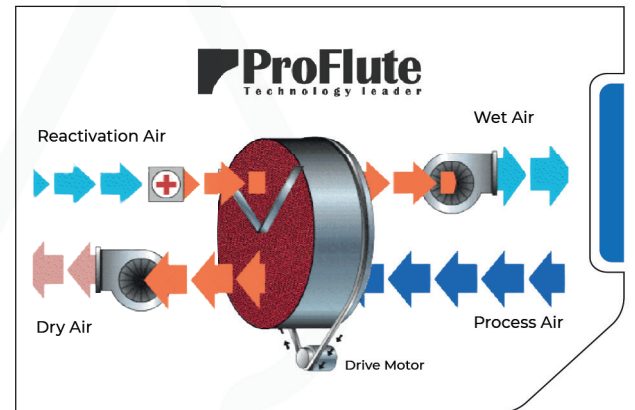
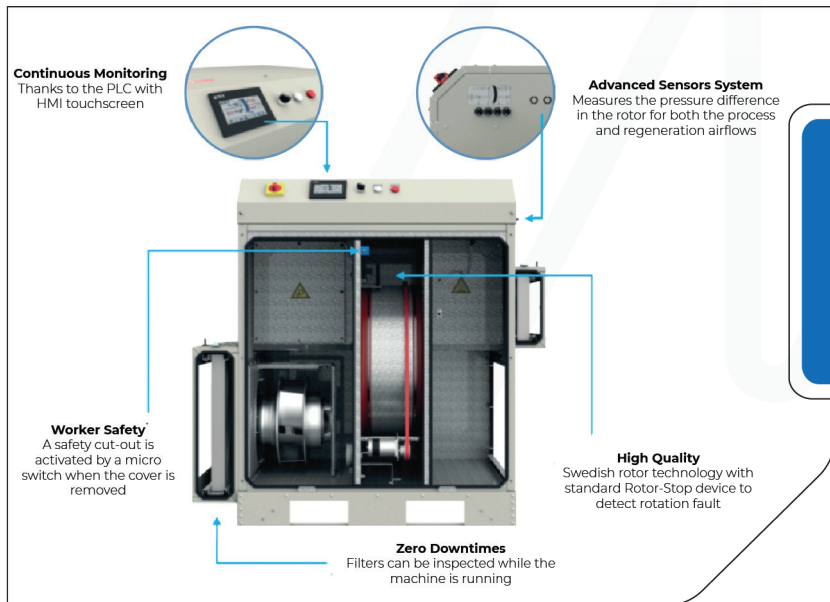

## CONDENSATION DEHUMIDIFIERS

- PROCESS AIR FLOW RATE UP TO 8500 M<sup>3</sup>/H

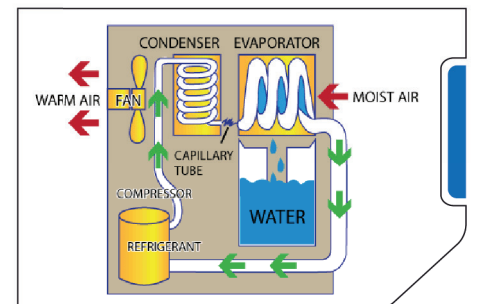

TSI IS A LEADING GLOBAL MANUFACTURER OF PRECISE AIR FLOW AND INDOOR AIR QUALITY INSTRUMENTS. TSI IS TRUSTED FOR ACCURATE HVAC TESTING & COMMISSIONING AND COMPLES WITH ASHRAE AND ISO STANDARDS.



## HVAC INSTRUMENTS



**AIR CAPTURE HOOD**



**MULTIFUNCTION**



**HYDRONIC MANOMETER**



**ROTATING VANE**



**MICROMANOMETER**



**ACCESSORIES**

**sauermann**<sup>®</sup>

SAUERMANN INSTRUMENTS ACCURATE RELIABLE PROFESSIONAL HIGH QUALITY INSTRUMENTS FOR MEASURING TEMPERATURE HUMIDITY PRESSURE AND AIRFLOW TRUSTED BY HVAC PHARMACEUTICAL .



**THERMO HYGROMETER  
RH-TEMP**



**DATA  
LOGGERS**

SANUVOX TECHNOLOGIES IS A GLOBAL LEADER IN UV AIR PURIFICATION PROVIDING ADVANCED AND COST-EFFECTIVE AIR PURIFICATION AND COIL CLEANING SYSTEMS THEIR PATENTED TECHNOLOGY MAXIMIZES UV EXPOSURE TIME TO ACHIEVE EXCEPTIONALLY HIGH PURIFICATION PERFORMANCE .



## ULTRAVIOLET LAMPS

### IL COIL CLEAN



- HIGH-EFFICIENCY UV SYSTEM
- LONG LAMP LIFE UP TO 17,000 HOURS
- CARB CERTIFICATION
- PREVENT BIOFILM AND MOLD GROWTH ON EVAPORATOR COILS

### QUATTRO

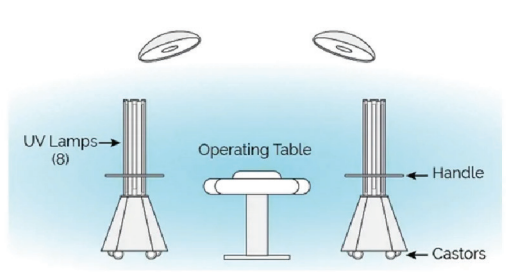

- UV AIR PURIFICATION FOR HVAC UP TO 5 TONS
- ENHANCED AIR DISINFECTION EFFICIENCY
- CARB CERTIFIED SYSTEM
- INSTALLED IN RETURN OR SUPPLY DUCT FOR MAXIMUM EXPOSURE

### ASEPT.2X

- DUAL UNITS, FULL COVERAGE
- MINIMIZED SHADOW AREAS
- DISINFECTION IN < 5 MINUTES
- HIGH-SPEED UV EFFICIENCY

# GENERAL PRODUCTS

## AHU ACCESSORIES

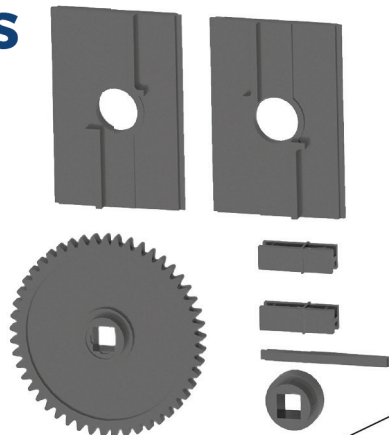

## AIR-AIR HEAT EXCHANGERS

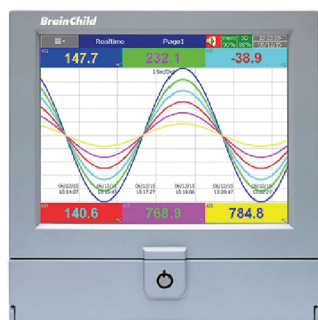

**CHART RECORDERS**



**PRESSURE GAUGES**



**DATA LOGGERS**

# SUCCESS STORIES



ADVANCED  
Engineering Solutions



**hikma.**



**Tanta Motors**  
ABOU FREIKHA 1950



**REDCON**  
CONSTRUCTION



**KORRAK**



# OUR PARTNERS

---

MICRONVIEW







# ADVANCED

## Engineering Solutions



**WEBSITE**

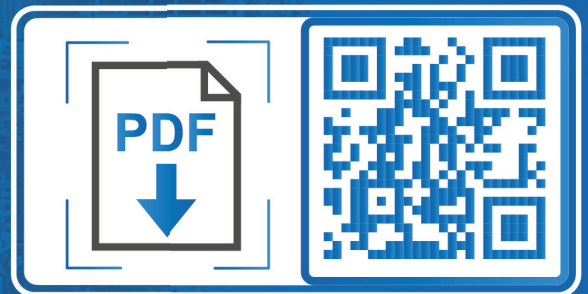

**GENERAL CATALOG**



**PHONE**

Phone : 0226203014  
Phone: 01028685161



**EMAIL**

info@advanced-eg.com  
sales@advanced-eg.com



**ADDRESS**

241 El Hegaz st. , El  
Nozha, Cairo